



Automotive Application ET01 Software
Revision A 12/06

INTRODUCTION	2
FUNCTIONAL DESCRIPTION	3
INSTALLATION	4
COMPONENT PLACEMENT	4
PLUMBING AND WIRING	5
MSBC OPERATION (ET-01)	14
TIMED BOOST CONTROL	16
RAMP FUNCTIONS	17
PROGRAMMING RAMPS	17
BOOST CONTROL MODES.....	19
TROUBLESHOOTING	20
APPENDIX A.....	21

IMPORTANT – The MSBC can only cause the engine to build boost within the operating envelope of your turbocharger/waste gate system. Your turbocharger/waste gate system has a minimum and maximum boost level. The MSBC will not change these limits. It will control boost within these limits. You must know and understand these characteristics before you can successfully gain the performance benefits of the MSBC.



Introduction

The MSBC-1 Multi Stage Boost Controller has been designed to allow the turbo charged vehicle owner to achieve the maximum vehicle potential in a controlled and repeatable manner.

With the growing popularity of fuel injection, turbo charging is rapidly becoming a favored method of achieving high power level in vehicles of all types. The flexibility of modern fuel injection systems has reduced the process of adding a turbocharger to that of a plumbing task. A special fuel delivery system is no longer required to make a turbo system work efficiently. A challenge still remains for the would-be turbo installer, that is matching all the parts of a turbo system so that they will work together in a desirable fashion. This includes choosing the right size turbo, turbo housings, impeller wheels, waste gate sizing, exhaust pipe sizing, and the list goes on. Creating and controlling boost is a symphony of functions affected by many components. One area of this challenge is especially complicated. And that is how to control a waste gate to create the desired power levels. Mechanical methods of waste control have been around for a long time and are useful to a degree. The downside of mechanical controls is that they vary from day to day, they vary with load on the engine, and they get very complicated if you need more than one stage of boost. Electronic waste gate controls have been around for a while but the products available have come from the high end of car racing such as Indy and F1.

The MSBC-1 has been designed to be a flexible electronic waste gate control solution for the performance street, dirt and drag race markets. The MSBC-1 has the multi stage and control flexibility to produce repeatable, controlled boost profiles with a variety of turbo systems and applications in a cost effective and easy to use package.



Functional Description

The MSBC-1 has the following features:

- Six stage programmable boost control.
- Useful for street, dirt or drag race applications.
- 0-80 PSI target boost range for each stage (1 PSI increments).
- Up to 18 different Ramp settings to control how fast boost is allowed to build.
- Launch stage for drag racing.
- Shift input for automatic stage selection for drag racing.
- 4 built-in timers for timed boost control.
- Front panel stage selection by driver for road or dirt use.
- Readout of actual boost during boost control.
- Built-In self test feature.
- Two analog data recorder outputs – Actual boost level, Target boost level.
- Two solenoid drive outputs – One Increase boost output, one Decrease boost output.
- Can be used with Single or Dual port waste gates.
- Uses electronic pressure sensor in manifold to monitor and control boost.
- Will force waste gate to produce preset target boost level even with air density, load, or mechanical variations.
- Can be used with manifold pressure only or external pressure source for control.



Installation

IMPORTANT – The MSBC can only cause the engine to build boost within the operating envelope of your turbocharger/waste gate system. Your turbocharger/waste gate system has a minimum and maximum boost level. The MSBC will not change these limits. It will control boost within these limits. You must know and understand these characteristics before you can successfully gain the performance benefits of the MSBC.

The MSBC can be setup to operate in several different configurations depending on your vehicle, race program and MSBC software. This Section covers the basic installation of your MSBC. Also included in this manual is a programming and operation section which includes automotive and motorcycle applications.

Component Placement

MSBC - In the drag race mode, access to the MSBC during operation is not necessary. Therefore, the MSBC may be placed in virtually any location. The mounting location should allow easy access to the display and pushbuttons. Additionally, avoid mounting locations that may expose your MSBC to extreme heat and/or electrical interference i.e. exhaust plumbing, ignition coils etc. Do not mount the MSBC in the engine compartment.

In the street mode, access to the MSBC display and push buttons **is** necessary during operation. In this mode the selection of stages and adjustment of boost level is performed manually by the driver. Placement on the dash or center console would be desired.

WARNING Do not place the MSBC-1 where it will obstruct the driver's view of the road or road conditions or present a physical challenge to operate manually.

Boost Sensor - The Boost Sensor is used to monitor the level of boost in the intake manifold. Placement on the firewall or other suitable frame tube near the intake manifold is desirable. Non-rigid mounting of the Boost Sensor is desirable such that engine and frame vibrations are not transferred directly into the sensor.

Mounting tips – Attaching a Velcro strip to the back of the MSBC and Boost Sensor to provide a quick and easy method for component mounting.

Solenoids – You need to determine if you are going to use one port or two-port waste gate control. In one port operation, increasing control pressure to the waste gate decreases the amount of boost the engine produces. In this mode the DECREASE solenoid routes manifold pressure to the waste gate causing it to open and decrease boost. The INCREASE solenoid serves to bleed off some of the pressure signal coming



from the manifold before it gets to the waste gate. The effect of this is to increase the amount of boost produced by the engine.

With two-port operation, the waste gate has two input fittings. One input to the waste gate will increase boost with added pressure. The other input to the waste gate will decrease boost with added pressure. In this case, manifold pressure is routed directly to the port that decreases boost. This port causes the waste gate valve to open as manifold pressure increases. The second port or control pressure port is used by the MSBC to control boost. In this configuration two solenoids are used with the MSBC. One solenoid adds pressure (INCREASE solenoid) to the control port to increase boost. The second solenoid (DECREASE solenoid) bleeds pressure off the control port to decrease boost. In the two-port mode, the control pressure source can be the manifold pressure or an external pressure source such as a CO2 bottle. If you are using an external source pressure, you must use a regulator in line to pre-regulate the pressure down to less than 100 PSI. In most cases the source pressure should be regulated down to the control pressure that will produce the **max** desired boost level if fed directly into the control port of the waste gate. This serves as a built in safety that will never let the engine over boost.

Plumbing and wiring

All MSBC related wiring should be routed together and away from excessive heat and electrical interference such as ignition coils and spark plug wiring. Care should be taken to route and secure wiring such that mechanical vibration does not cause chaffing or short circuits over time.

Wiring Tips:

- A good mechanical connection is a good electrical connection.
- Just because a connection was good enough to work once in the shop, doesn't mean it will stand up to the stress and vibration of race day.
- For power & ground to electronic systems, Do not rely upon the vehicle body or frame as a substitute for a ground wire from the battery.
- Always use the correct crimping tool for the corresponding lugs. Crushing a lug with a pair of pliers will not result in a good connection
- Twisting wires together and using electrical tape is not a good connection.
- The more crimped lugs you "stack up" under a screw or bolt the greater the chance a bad connection will surface on race day.

Plumbing should be routed directly, minimizing excessive tubing and should be firmly secured to avoid pressure leakage due to mechanical shock and vibration. **Leaks** in the system will cause sub optimal performance. Use of thread compound on control pressure fittings and zip ties on boost sensor tubing is recommended.



Note the exhaust port (EXH) plug called for in the following instructions



Correct Wire Crimp



Control Side of Wastegate



Lift Side of Wastegate

Wiring -

Power Cable connector – Locate the harness in your kit that has a four position connector at one end. One leg of the harness contains a BLACK and RED wire. Connect the RED wire to a source of switched 12 volts such as ignition power. Connect the BLACK wire to a good vehicle harness ground wire or directly to the battery. The second leg of this harness contains the INCREASE/DECREASE solenoid wires. Route these wires to the boost solenoid(s).

Solenoid wiring - Use the BLUE wire for the INCREASE solenoid and the GRAY wire for the DECREASE solenoid. Locate 4 socket terminals and 2 socket connector bodies. Trim wires to length. Attach one socket terminal to the BLUE wire. Attach one socket terminal to the GRAY wire. Both solenoids require a connection to the RED wire. To do this, loop the RED wire from the DECREASE solenoid connection to the INCREASE solenoid. Attach one socket terminal to the free end of the RED loop wire. Insert it and the BLUE wire into a socket connector body. Plug this connector into the INCREASE solenoid. Insert the other RED wire and the GRAY wire into a socket connector body and plug it into the DECREASE solenoid. It should look like the figure below. (Also see figures 2 and 3)



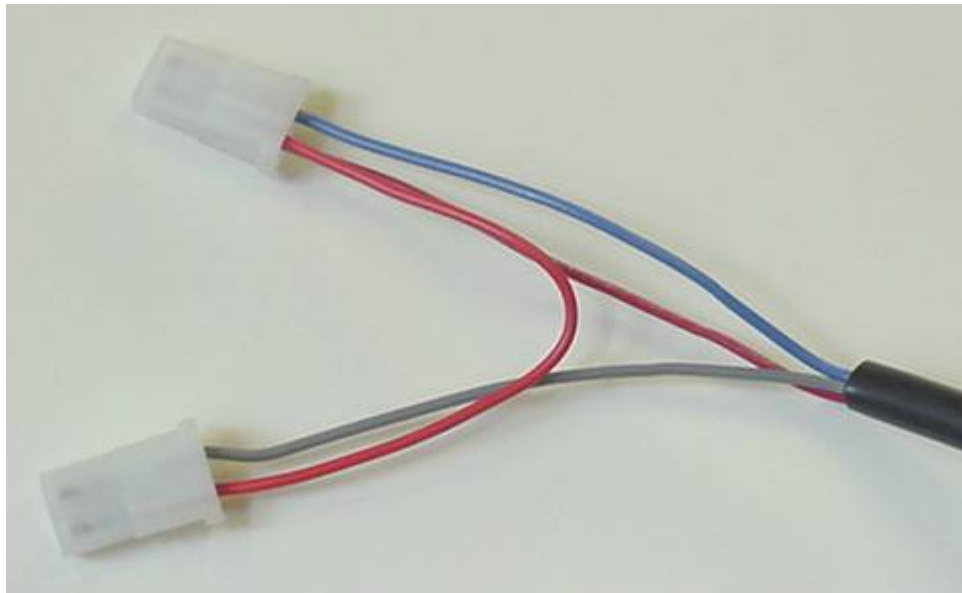

Solenoid Wiring

Boost Sensor connector - This connector is used to connect the MSBC to the Boost Sensor. The Boost Sensor is pre wired for direct connection to the MSBC. Simply plug it in.

Race Input connector - This is the connector that is used to interface the shift and launch inputs to the MSBC. These are the inputs that enable the automatic stage increment feature for drag racing. The GRAY wire is the Shift input. The MSBC will automatically change from one stage to the next when a momentary +12 Volts is applied to this input. This signal could be from a switch connected to the clutch pedal or shifter assembly. If you want to use the automatic shift feature, connect the GRAY wire to one side of a normally open switch and switched +12 Volts to the other side of the switch. Mount the switch in such a way that it will momentarily be pressed during the shift.

The MSBC also has a Launch stage, 2-Step feature, which can be used to select starting line boost for drag racing applications. To activate the Launch stage, switch +12 volts to the BROWN wire. In this mode the L led will illuminate. The Launch signal could come from a switch on the clutch pedal or a trans brake switch or any other switch active during staging. This wiring is the same for single and dual port waste gate applications.



The YELLOW wire is used to select manifold mode or wastegate gate mode. With the YELLOW wire unused the system is in manifold mode. This means the MSBC is monitoring manifold air directly and will not begin boost control until boost is greater than 3psi. With the YELLOW wire connected to ground the system is in wastegate mode. This means the MSBC MAP sensor is plumbed to monitor waste gate control air and begins regulation as soon as this wire grounded.

Note: In waste gate mode the target boost settings are NOT manifold boost. Boost is indirectly controlled by regulating the amount of control air supplied to the wastegate. This method requires a complete knowledge of the relationship between control air and manifold pressure for your vehicle. I.e. X psi on the wastegate equals Y psi in the manifold.

Note: The Race inputs change functionality depending on the MSBC software in use. Please see the programming and operation sections at the end of this manual for more information.

Note: The 2-Step launch feature can be activated from ANY other stage.

Data Recorder connector - This connector provides two data recorder outputs to assist with vehicle tuning. The ORANGE wire is a signal representing the actual boost level. This is the signal out of the Boost Sensor. The GREEN wire is a signal representing the current Target Boost level selected. This is the current boost level that the MSBC is trying to achieve. These outputs are 0-5 volt signals. See appendix A.



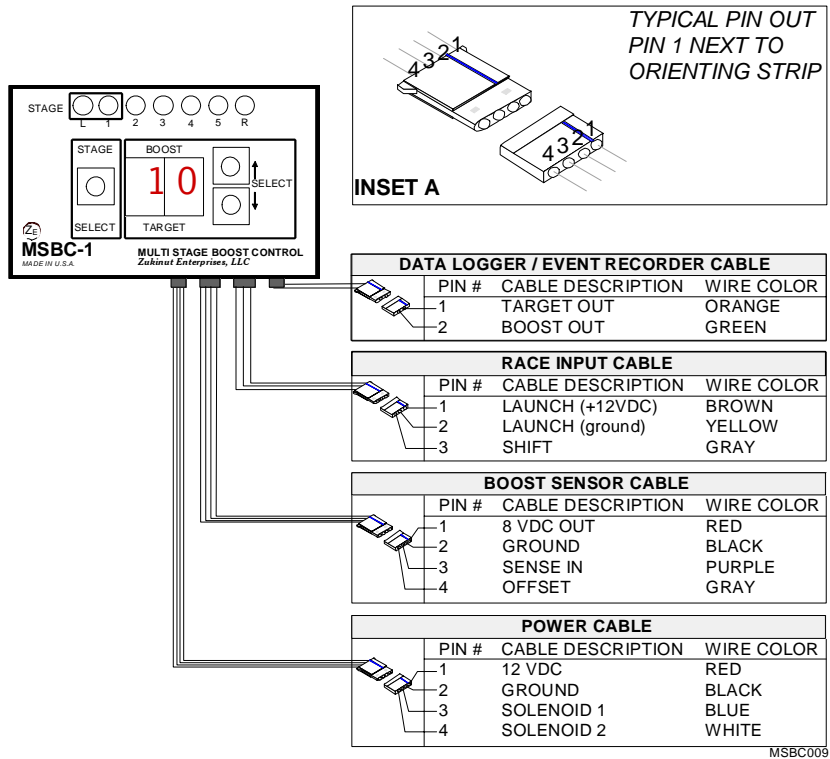
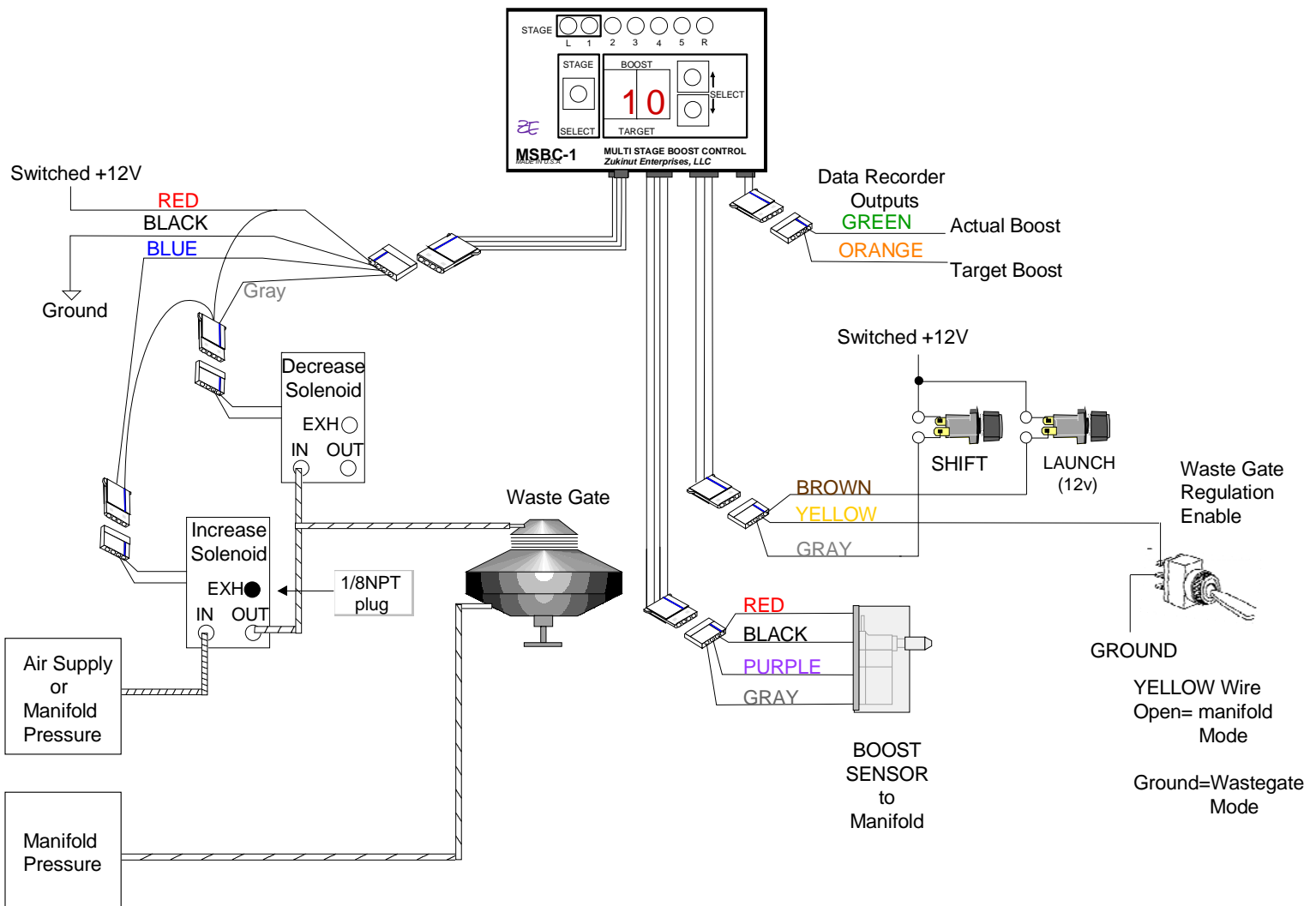
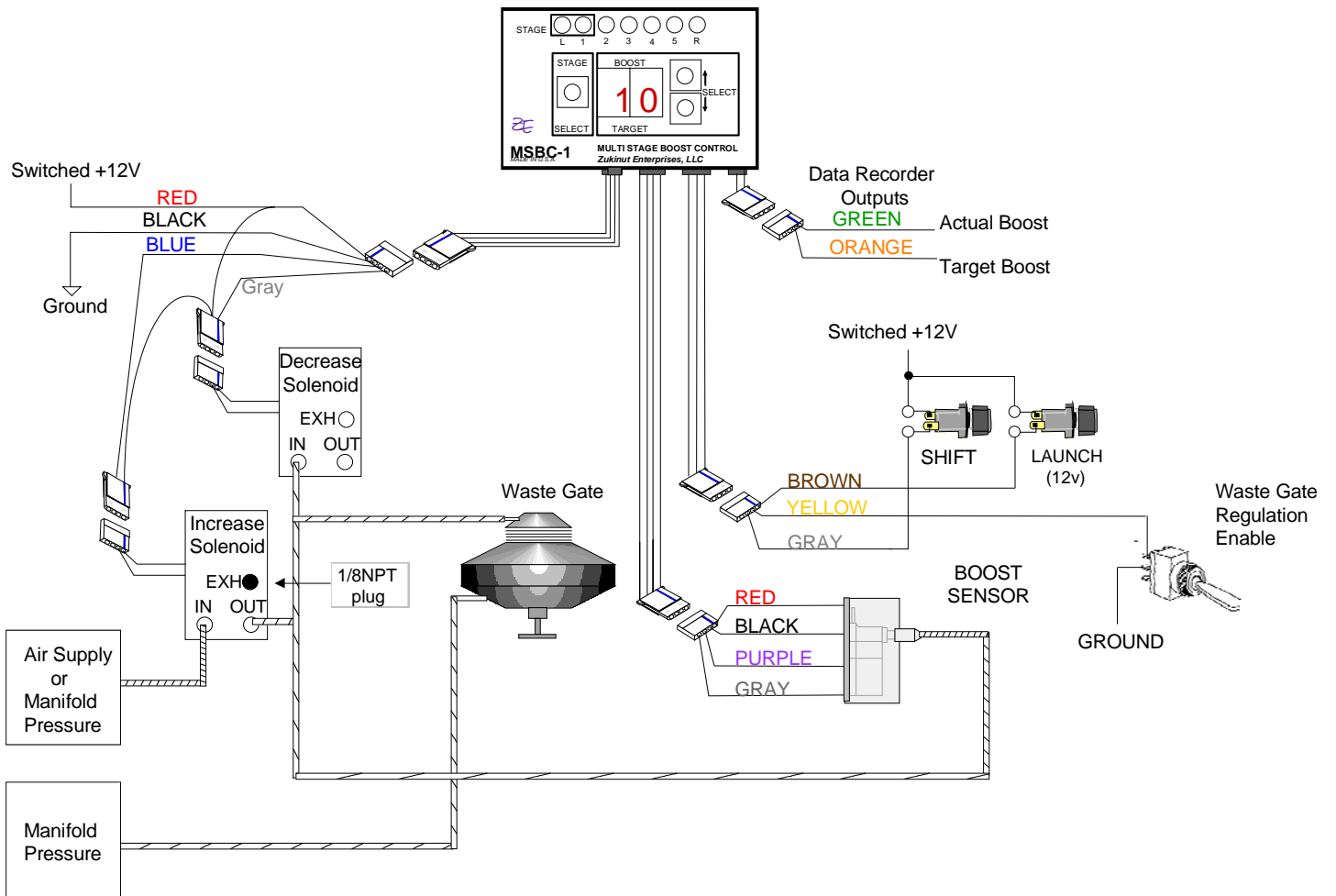

Figure 1. MSBC connector description.



Dual Port, Manifold Mode





Dual Port, Wastegate Mode



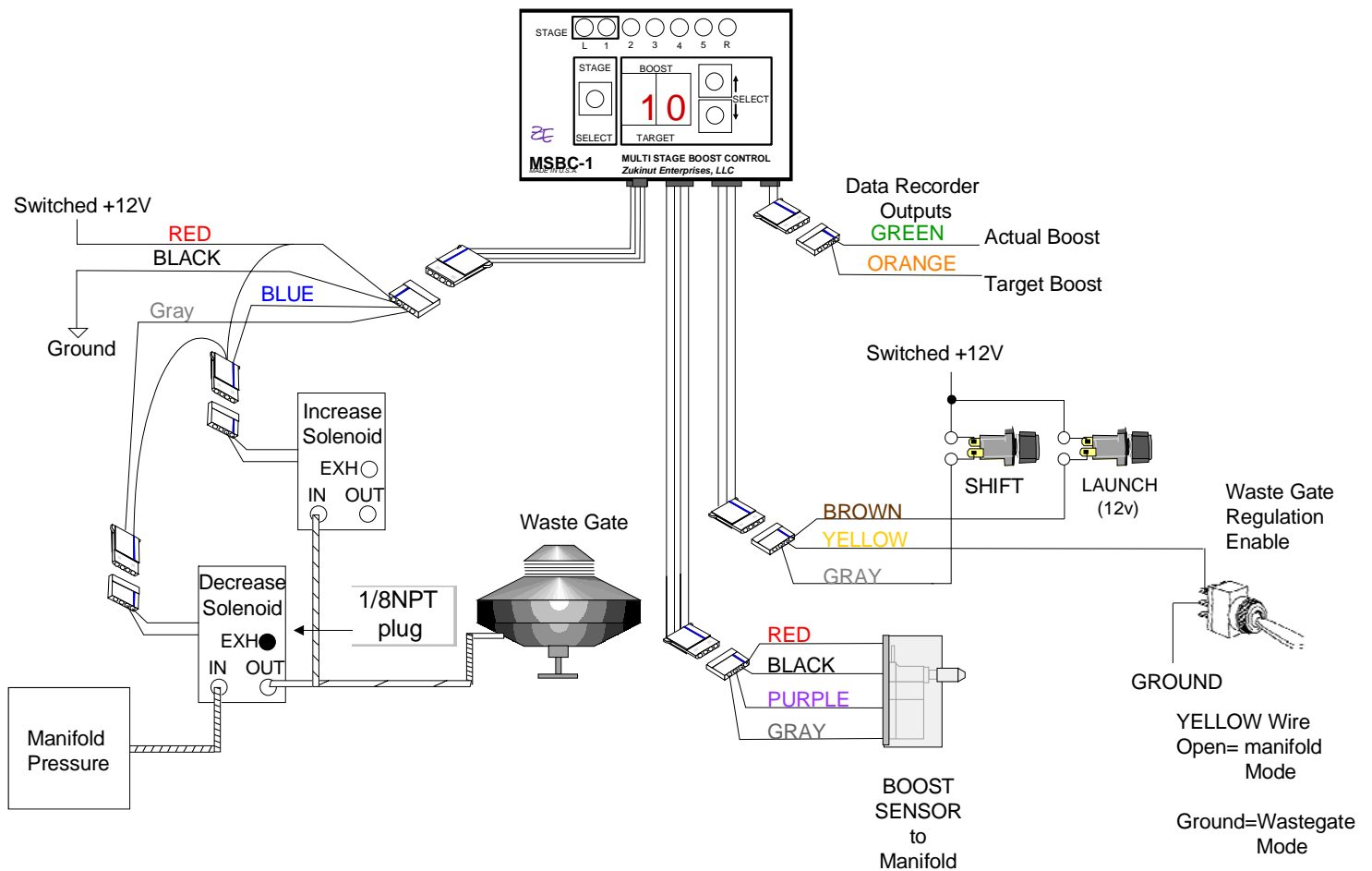

Single Port, Wastegate Mode



MSBC Operation (ET-01)

IMPORTANT – The MSBC can only cause the engine to build boost within the operating envelope of your turbocharger/waste gate system. Your turbocharger/waste gate system has a minimum and maximum boost level. The MSBC will not change these limits. It will control boost within these limits. You must know and understand these characteristics before you can successfully gain the performance benefits of the MSBC.

ET-01, incorporates the addition of a new user programmable 2 Stage ramp function, #18. The 2 stage ramp is made up of a starting ramp, ending ramp and a percent of target switch point. The first and second stages can be any one of ramps 0 -9 with a percentage switch point of 50, 60 or 70 percent. For example: With a target of 20psi, percent of 70, first stage ramp of 1 and second stage ramp of 9. The boost will build at a rate of 45psi/S until the boost reaches 17psi and then switch to ramp 9 at 3psi/S. This programmability results in 273 boost control combinations.

Programming 2-Stage RAMP parameters:

Press and hold the SELECT key while powering up the MSBC. Release the SELECT key when the display flashes 00.

The first number displayed applies to the first stage of the 2 stage ramp. Possible choices are ramps

0 – 9. Use the UP and DOWN keys to select the desired ramp.

Press the SELECT key again. The displayed number applies to the second stage of the 2 stage ramp. Possible choices are ramps 0 - 9. Use the UP and DOWN keys to select the desired ramp.

Press the SELECT key again. This number governs the point at which the MSBC switches from the first ramp to the second. This switch point is a percentage of the target boost for the stage being programmed. Possible choices are 50, 60 and 70 percent. Use the UP and DOWN keys to select the desired percentage.

Press the SELECT key again to exit the programming menu.

Assigning the 2-Stage RAMP to a stage:

Press and hold the SELECT key while Pressing the UP key. The RAMP led comes ON.

Press the SELECT key to advance to the desired stage.

Use the UP and DOWN keys to set the ramp to 18.

To exit Ramp programming mode, Press and hold the SELECT key while Pressing the UP key.



Note: Ramps 0 -17 can be assigned to any of the other stages.

Note: Ramp 18 can be assigned to multiple stages but the parameters set at power up will apply to all stages.

Note: The 2 stage programming menu can also be accessed by holding the SELECT key down when switching out of Wastegate mode.

Note: The metal air inlet MAP sensor uses the same electrical connector and operates on the same power supply as previous MSBC sensors in order to maintain backward compatibility but must be used with software version TURBO12H or ET-01.

Stage LEDs - These LED indicators are used to display the current stage (gear).

L = launch – In drag race mode this stage controls the boost at launch and is controlled by the launch input (clutch) and shifts to Stage 1 when the clutch is released. The MSBC can be returned to the LAUNCH stage from any stage by re-activating the LAUNCH input.

Stage 1 – 5 – Allows selection of individual target boost for each stage. In drag race mode the MSBC advances to each stage with each activation of the shift input. Once the system reaches stage 5, further activations of the shift input will be ignored. The select key can be used to manually wrap the stage around to Launch or Stage 1 depending on the status on the clutch. (in or out).

R = Ramp. Used to program the rate at which the boost is allowed to build.

Stage Select – Used to manually select between launch, stages 1- 5.

Select UP/Down – Used to INCREASE or DECREASE the target boost as displayed on the 7-segment display. Each boost stage can be set to any value up to 60 PSI

7-segment display – Used to display target boost settings and actual boost when the MSBC is active.

Dimmer – A dimmer feature is built into the MSBC such that the intensity of the LEDs and the 7-segment display is reduced in low light conditions.



Timed Boost Control

The MSBC provides 4 timers that govern the transition through Stages 1 – 5. These timers are adjustable in 0.01 seconds increments for a total per stage time of 4.99 seconds. The time sequence is activated by release of the built-in 2-step. (LAUNCH input) All timer functions are reset if the 2-Step is reactivated. The MSBC will allow manual shift and TIMED control to operate at the same time. This means a timed stage can be short shifted manually or part of the run can be timed while another portion can be manual.

Programming Timed Boost Mode:

- a. Press and hold the SELECT key
- b. Press the DOWN key.
- c. Stage 1 led is ON. Unit is ready to set Stage 1 timer seconds (0 – 4)
- d. Use the UP and DOWN keys to set the stage 1 to stage 2 transition time.
- e. Press the SELECT key again. To set the x.00 time for Stage 1. (0.99)
- f. Repeat steps C and D for the remaining timers.

Exit TIMER Mode:

- a. Press and hold the SELECT key
- b. Press the DOWN key.

Note the operation of the decimal points when pressing SELECT key.

To select the other timers simply use the SELECT key.

To skip a stage(s) set the time value to zero. ALL values 0.00.



Ramp Functions

The MSBC-1 offers 18 ramp functions. Ramps 0 – 9 are single stage functions that allow boost to build at a fixed psi/second rate. (see table 1) Ramps 10 – 17 are composed of a 2-stage ramp function that allows boost to build rapidly for the first 70% of the ramp and then switch to a slower rate for the final 30%. The initial rate for these 2-stage ramps is 40 psi/sec, while the final 30% can be programmed for rates from 20 to 2 psi/sec. See 2-stage ramp example 1.

Programming Ramps

- a. Press and hold the SELECT key
- b. While holding the SELECT key down, press the UP key.
- c. The Ramp led will come on indicating that the Ramp mode has been entered.
- d. The LAUNCH stage led will be on. The numeric display will indicate the Ramp setting for this stage. Use the UP and DOWN keys to select the desired ramp for this stage.
- e. Press the SELECT key again. Note that the Stage 1 led is on and the numeric display is indicating the ramp setting for that stage. Again use the UP and DOWN keys to select the desired ramp. Repeat this procedure for the remaining stages.

To exit Ramp mode:

- a. Press and hold the SELECT key.
- b. While holding the SELECT key down, press the UP key.
- c. The RAMP led will go off indicating that the RAMP mode has been exited.
- d. The MSBC will return to Target Boost mode for Stage 1.

Note: The 2-stage ramps were designed to provide greater boost control for vehicles with fast build, high boost turbo systems during the initial stages of a run. I.e. Launch and 1st. If used in applications where the boost build is slow and/or the target boost setting is small from stage to stage the ramp function may not be noticeable. In this case using ramps 0 – 9 is preferred.

Note: If the MSBC is left in Ramp mode and boost goes above 3psi the unit will exit ramp mode automatically and display real time boost readings.



RAMP#	RAMP RATE
0	= no rate control. (fastest rate of build)
1	= 40PSI/second max
2	= 20PSI/second max
3	= 15PSI/second max
4	= 12PSI/second max
5	= 10PSI/second max
6	= 8PSI/second max
7	= 6PSI/second max
8	= 4PSI/second max
9	= 2PSI/second max

2-Stage Ramp Example 1.

Example:
 Target = 25psi
 Pivot point = 17psi

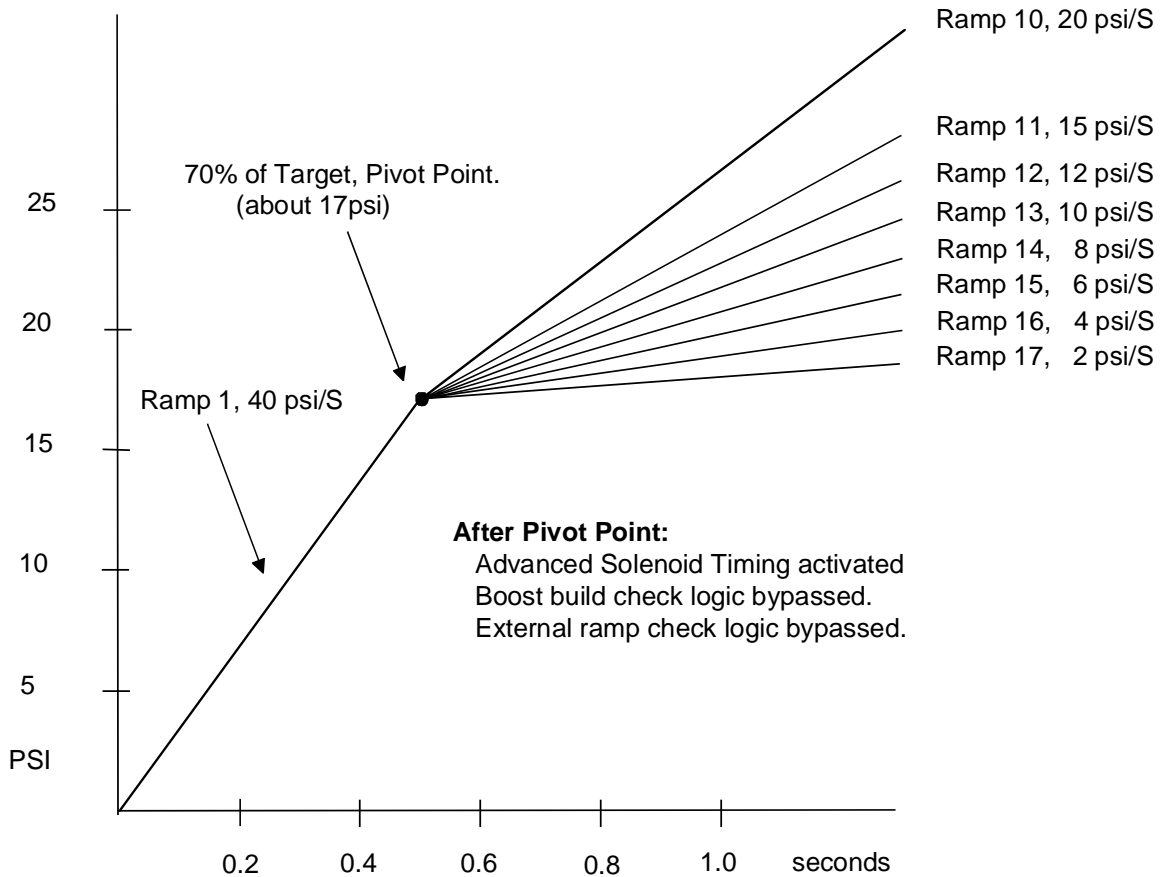

Boost Control Modes

The YELLOW wire on the MSBC is the boost regulation mode select input. This input allows selection between manifold or wastegate control mode. When the YELLOW wire is switched to ground, the MSBC is set for wastegate mode and begins boost control immediately. In this configuration the boost sensor is plumbed to the top or control side of a dual port wastegate. Boost is indirectly controlled by regulating the amount of control air supplied to the wastegate. This method requires a complete knowledge of the relationship between control air and manifold pressure for your vehicle. I.e. X psi on the wastegate equals Y psi in the manifold. Removing the ground on the YELLOW will cause the MSBC to vent control air for about 4 seconds and discontinue boost control. When the YELLOW wire is left unused, the MSBC is set for Manifold mode. In this mode the MAP sensor is plumbed to the manifold and boost must go above 3 psi before the MSBC-1 will begin the control boost.

Note: Use of a high quality, high reliability mode select switch is strongly recommended.

Note: Setting a stage to ZERO target will cause the DECREASE solenoid to be on continuously.



Troubleshooting

Apply power to the MSBC WHILE holding down the DOWN key to enter the self-test mode. The MSBC will perform tests on the display, boost sensor input, solenoid outputs and the data logger output. The display and data logger tests are not interactive and require you to watch the progression and determine if a problem exists. The boost sensor, solenoid and data logger tests are interactive meaning that if a problem is detected the unit remains at that step blinking the error code until the defect is corrected.

- a. Each LED will be lit one at a time starting with the L led.
- b. Each 7-segment display will count 0 to 9.
- c. Left and right decimal points
- d. Each solenoid output is tested for open circuit, too low and too high drive level.
- e. Boost sensor is tested for too low and too high value at ambient pressure (zero boost, engine off).
- f. Data logger output is stepped through 9 test values with the corresponding boost value displayed. 10, 15, 20, 30, 40, 50, 70, 80 psi.

Error codes:

Code 1 - Boost sensor reading too high or low for zero boost. Check wiring/sensor/MSBC.

Code 2 - INCREASE solenoid output shorted. Check MSBC

Code 3 - INCREASE solenoid level too low. check wiring/solenoid/LOW battery/MSBC

Code 4 - INCREASE solenoid level too high. check wiring/solenoid.

Code 5 - DECREASE solenoid output shorted. Check MSBC

Code 6 - DECREASE solenoid level too low. check wiring/solenoid/LOW battery/MSBC

Code 7 - DECREASE solenoid level too high. check wiring/solenoid.



Appendix A

